

# SERVICE & OPERATING MANUAL

## ORIGINAL INSTRUCTIONS

# E4

### 1 1/2" Elima-Matic Bolted Plastic with Metal Center Section

#### E4 Plastic Pumps

- Polypropylene
- PVDF

EAC CE UK  
CA

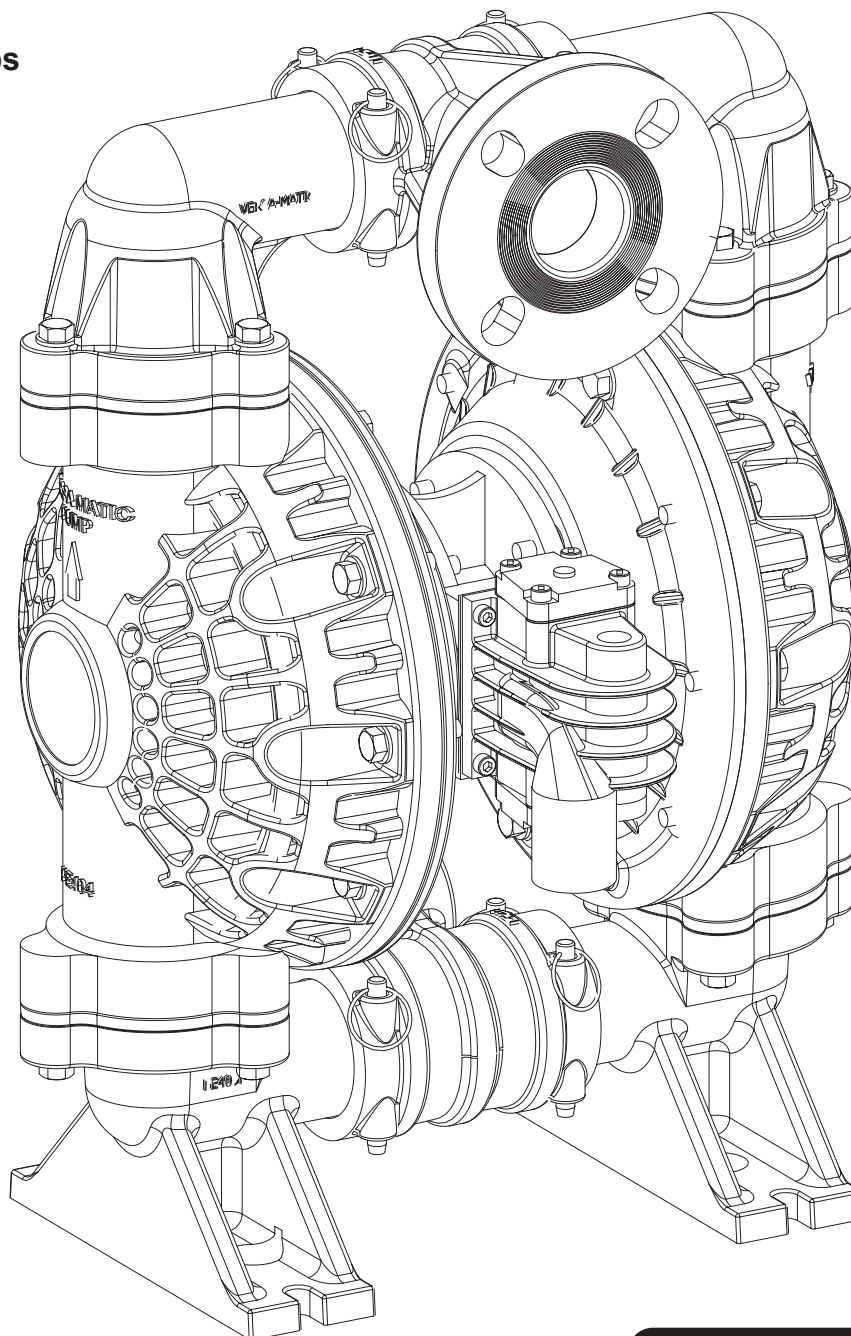

1: PUMP SPECS

2: INSTAL & OP

3: EXP VIEW

4: WARRANTY



**VERSAMATIC®**

# Safety Information

## IMPORTANT



Read the safety warnings and instructions in this manual before pump installation and start-up. Failure to comply with the recommendations stated in this manual could damage the pump and void factory warranty.



When the pump is used for materials that tend to settle out or solidify, the pump should be flushed after each use to prevent damage. In freezing temperatures the pump should be completely drained between uses.

## CAUTION



Before pump operation, inspect all fasteners for loosening caused by gasket creep. Retighten loose fasteners to prevent leakage. Follow recommended torques stated in this manual.



Plastic pumps and plastic components are not UV stabilized. Ultraviolet radiation can damage these parts and negatively affect material properties. Do not expose to UV light for extended periods of time.



### WARNING

Pump not designed, tested or certified to be powered by compressed natural gas. Powering the pump with natural gas will void the warranty.



### WARNING

The use of non-OEM replacement parts will void (or negate) agency certifications, including CE, ATEX, CSA, 3A and EC1935 compliance (Food Contact Materials). Warren Rupp, Inc. cannot ensure nor warrant non-OEM parts to meet the stringent requirements of the certifying agencies.

## WARNING



When used for toxic or aggressive fluids, the pump should always be flushed clean prior to disassembly.



Before maintenance or repair, shut off the compressed air line, bleed the pressure, and disconnect the air line from the pump. Be certain that approved eye protection and protective clothing are worn at all times. Failure to follow these recommendations may result in serious injury or death.



Airborne particles and loud noise hazards. Wear eye and ear protection.



In the event of diaphragm rupture, pumped material may enter the air end of the pump, and be discharged into the atmosphere. If pumping a product that is hazardous or toxic, the air exhaust must be piped to an appropriate area for safe containment.



Take action to prevent static sparking. Fire or explosion can result, especially when handling flammable liquids. The pump, piping, valves, containers and other miscellaneous equipment must be properly grounded.



This pump is pressurized internally with air pressure during operation. Make certain that all fasteners and piping connections are in good condition and are reinstalled properly during reassembly.



Use safe practices when lifting

## ATEX Pumps - Conditions For Safe Use

1. Ambient temperature range is as specified in tables 1 & 2 on the next page
2. ATEX compliant pumps are suitable for use in explosive atmospheres when the equipment is properly grounded in accordance with local electrical codes
3. Conductive Polypropylene, conductive Acetal or conductive PVDF pumps are not to be installed in applications where the pumps may be subjected to oil, greases and hydraulic liquids.
4. When operating pumps equipped with non-conductive diaphragms that exceed the maximum permissible projected area, as defined in EN ISO 80079-36 : 2016 section 6.7.5 table 8, the following protection methods must be applied
  - Equipment is always used to transfer electrically conductive fluids or
  - Explosive environment is prevented from entering the internal portions of the pump, i.e. dry running.

# Table of Contents

## **SECTION 1: PUMP SPECIFICATIONS .....1**

- Nomenclature
- Performance
- Materials
- Dimensional Drawings

## **SECTION 2: INSTALLATION & OPERATION ...7**

- Principle of Pump Operation
- Typical Installation Guide
- Troubleshooting

## **SECTION 3: EXPLODED VIEW.....10**

- Composite Drawings
- Parts List
- Materials Code

## **SECTION 4: WARRANTY & CERTIFICATES ..13**

- Warranty
- EU Declaration of Conformity - Machinery Directive

1: PUMP SPECS

2: INSTAL & OP

3: EXP VIEW

4: WARRANTY

# Explanation of Pump Nomenclature

Your Serial #: (fill in from pump nameplate) \_\_\_\_\_

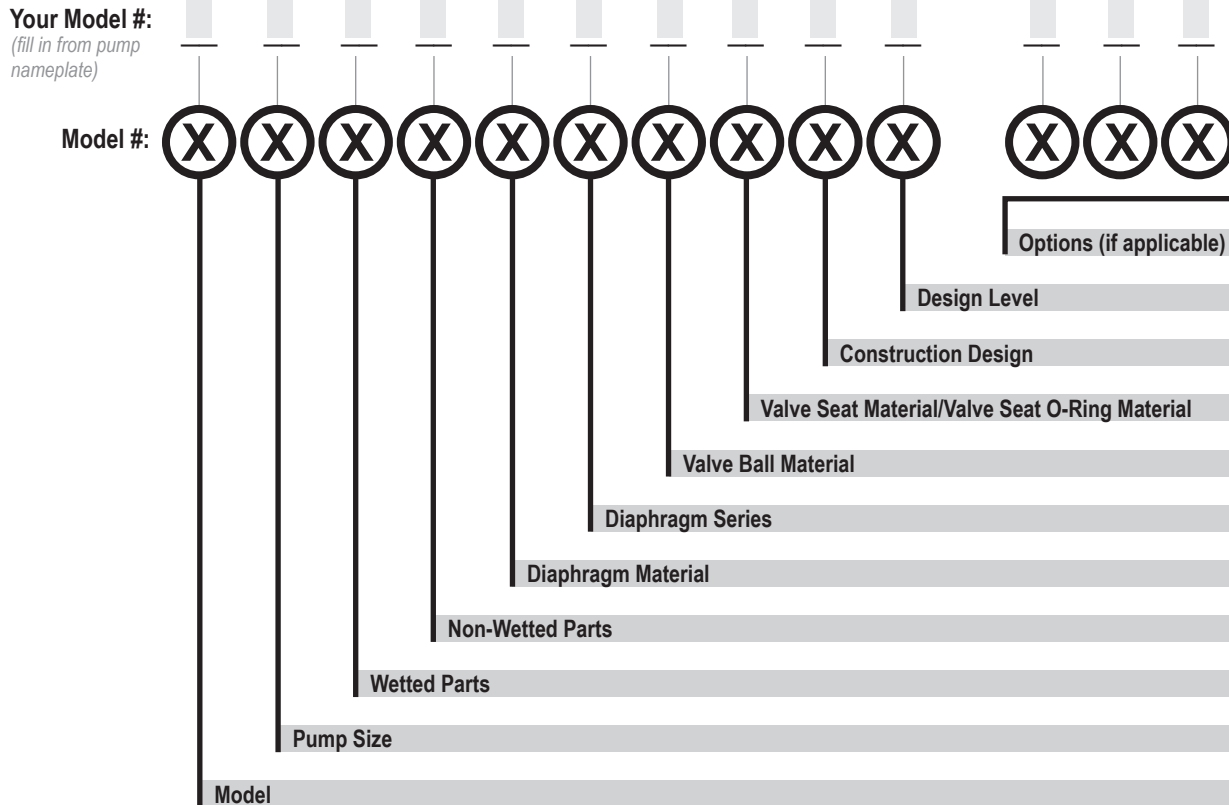

1: PUMP SPECS

Model	Pump Size	Wetted Parts	Non-Wetted Parts	Diaphragm Material
E Elima-Matic	6 1/4"	A Aluminum	A Aluminum	1 Neoprene
U Ultra-Matic	8 3/8"	C Cast Iron	S Stainless Steel	2 Nitrile (Nitrile)
V V-Series	5 1/2"	S Stainless Steel	P Polypropylene	3 FKM (Fluorocarbon)
	7 3/4"	H Alloy C	G Groundable Acetal	4 EPDM
	1 1"	P Polypropylene	Z PTFE-coated Aluminum	5 PTFE
	4 1-1/4" or 1-1/2"	K Kynar	J Nickel-plated Aluminum	6 Santoprene XL
	2 2"	G Groundable Acetal	C Cast Iron	7 Hytrel
	3 3"	B Aluminum (screen mount)	Q Epoxy-Coated Aluminum	Y FDA Santoprene

Diaphragm Series	Valve Ball Material Valve	Seat/Valve Seat O-Ring Material	Construction Design	Miscellaneous Options
R Rugged	1 Neoprene	1 Neoprene	9 Bolted	B BSP Tapered Thread
D Dome	2 Nitrile	2 Nitrile	0 Clamped	CP Center Port
X Thermo-Matic	3 (FKM) Fluorocarbon	3 (FKM) Fluorocarbon		ATEX ATEX Compliant
T Tef-Matic (2-piece)	4 EPDM	4 EPDM		FP Food Processing
B Versa-Tuff (1-piece)	5 PTFE	5 PTFE		SP Sanitary Pump
F FUSION (one-piece integrated plate)	6 Santoprene XL	6 Santoprene XL		HP High Pressure
	7 Hytrel	7 Hytrel		OE Original Elima-Matic
	8 Polyurethane	8 Polyurethane		F Flap Valve
	A Acetal	A Aluminum w/ PTFE O-Rings		HD Horizontal Discharge
	S Stainless Steel	S Stainless Steel w/ PTFE O-Rings		3A 3-A Certified
	Y FDA Santoprene	C Carbon Steel w/ PTFE O-Rings		UL UL Listed
		H Alloy C w/ PTFE O-Rings		OB Oil Bottle
		T PTFE Encapsulated Silicone O-Rings		
		Y FDA Santoprene		

\*More than one option may be specified for a particular pump model.

# Materials

Material Profile:	Operating Temperatures:	
	Max.	Min.
<b>CAUTION!</b> Operating temperature limitations are as follows:		
<b>Conductive Acetal:</b> Tough, impact resistant, ductile. Good abrasion resistance and low friction surface. Generally inert, with good chemical resistance except for strong acids and oxidizing agents.	190°F 88°C	-20°F -29°C
<b>EPDM:</b> Shows very good water and chemical resistance. Has poor resistance to oils and solvents, but is fair in ketones and alcohols.	280°F 138°C	-40°F -40°C
<b>FKM:</b> (Fluorocarbon) Shows good resistance to a wide range of oils and solvents; especially all aliphatic, aromatic and halogenated hydrocarbons, acids, animal and vegetable oils. Hot water or hot aqueous solutions (over 70°F) will attack FKM.	350°F 177°C	-40°F -40°C
<b>Hytrel®:</b> Good on acids, bases, amines and glycols at room temperatures only.	220°F 104°C	-20°F -29°C
<b>Neoprene:</b> All purpose. Resistance to vegetable oils. Generally not affected by moderate chemicals, fats, greases and many oils and solvents. Generally attacked by strong oxidizing acids, ketones, esters and nitro hydrocarbons and chlorinated aromatic hydrocarbons.	200°F 93°C	-10°F -23°C
<b>Nitrile:</b> General purpose, oil-resistant. Shows good solvent, oil, water and hydraulic fluid resistance. Should not be used with highly polar solvents like acetone and MEK, ozone, chlorinated hydrocarbons and nitro hydrocarbons.	190°F 88°C	-10°F -23°C
<b>Nylon:</b> 6/6 High strength and toughness over a wide temperature range. Moderate to good resistance to fuels, oils and chemicals.	180°F 82°C	32°F 0°C

<b>Polypropylene:</b> A thermoplastic polymer. Moderate tensile and flex strength. Resists strong acids and alkali. Attacked by chlorine, fuming nitric acid and other strong oxidizing agents.	180°F 82°C	32°F 0°C
<b>PVDF:</b> (Polyvinylidene Fluoride) A durable fluoroplastic with excellent chemical resistance. Excellent for UV applications. High tensile strength and impact resistance.	250°F 121°C	0°F -18°C
<b>Santoprene®:</b> Injection molded thermoplastic elastomer with no fabric layer. Long mechanical flex life. Excellent abrasion resistance.	275°F 135°C	-40°F -40°C
<b>UHMW PE:</b> A thermoplastic that is highly resistant to a broad range of chemicals. Exhibits outstanding abrasion and impact resistance, along with environmental stress-cracking resistance.	180°F 82°C	-35°F -37°C
<b>Urethane:</b> Shows good resistance to abrasives. Has poor resistance to most solvents and oils.	150°F 66°C	32°F 0°C
<b>Virgin PTFE:</b> (PFA/TFE) Chemically inert, virtually impervious. Very few chemicals are known to chemically react with PTFE; molten alkali metals, turbulent liquid or gaseous fluorine and a few fluoro-chemicals such as chlorine trifluoride or oxygen difluoride which readily liberate free fluorine at elevated temperatures.	220°F 104°C	-35°F -37°C
<i>Maximum and Minimum Temperatures are the limits for which these materials can be operated. Temperatures coupled with pressure affect the longevity of diaphragm pump components. Maximum life should not be expected at the extreme limits of the temperature ranges.</i>		
<b>Metals:</b>		
<b>Alloy C:</b> Equal to ASTM494 CW-12M-1 specification for nickel and nickel alloy.		
<b>Stainless Steel:</b> Equal to or exceeding ASTM specification A743 CF-8M for corrosion resistant iron chromium, iron chromium nickel and nickel based alloy castings for general applications. Commonly referred to as 316 Stainless Steel in the pump industry.		

1: PUMP SPECS

For specific applications, always consult the Chemical Resistance Chart.

**Note:** This document is a high level guide. Please be aware that not all model and or material combinations are possible for all sizes. Please consult factory or your distributor for specific details.

# Performance

## E4 1 1/2" Bolted Plastic Pump ELASTOMERIC AND TPE FITTED

### Flow Rate

Adjustable to . . . . . 0-75 gpm (284 lpm)

### Port Size

Suction . . . . . 1 1/2" ANSI

Discharge . . . . . 1 1/2" ANSI

**Air Inlet** . . . . . 1/2" NPT

**Air Exhaust** . . . . . 3/4" NPT

### Suction Lift

Dry . . . . . 17' (5.2 m)

Wet . . . . . 26' (7.9 m)

### Max Solid Size (Diameter)

. . . . . 3/16" (4.76 mm)

**Max Noise Level** . . . . . 89 dB(A)

### Shipping Weights

Polypropylene . . . . . 40 lbs (18 kg)

Kynar . . . . . 41 lbs (18.6 kg)

1: PUMP SPECS

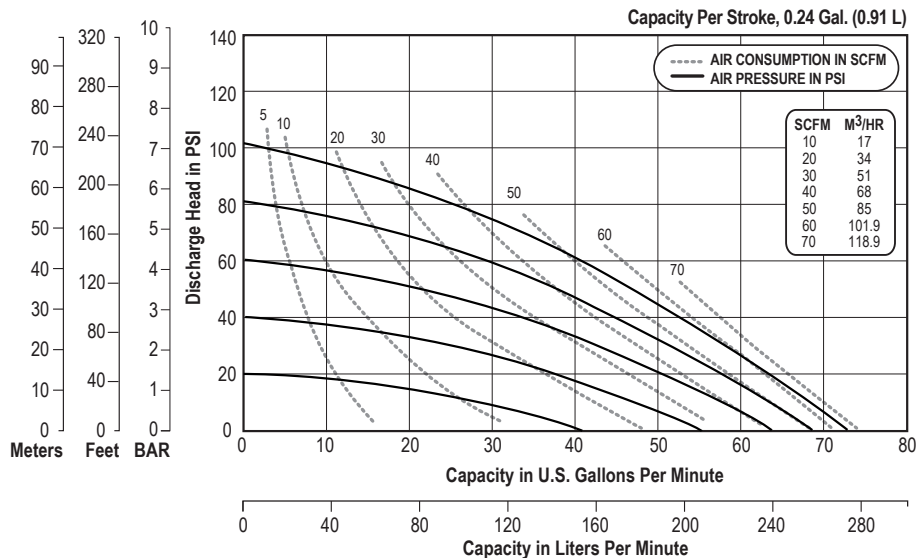

NOTE: Performance based on the following: elastomeric fitted pump, flooded suction, water at ambient conditions. The use of other materials and varying hydraulic conditions may result in deviations in excess of 5%.

## E4 1 1/2" Bolted Plastic Pump PTFE Fitted

### Flow Rate

Adjustable to . . . . . 0-72 gpm (272.5 lpm)

### Port Size

Suction . . . . . 1 1/2" ANSI

Discharge . . . . . 1 1/2" ANSI

**Air Inlet** . . . . . 1/2" NPT

**Air Exhaust** . . . . . 3/4" NPT

### Suction Lift

Dry . . . . . 10' (3.0 m)

Wet . . . . . 27' (8.2 m)

### Max Solid Size (Diameter)

. . . . . 3/16" (4.76 mm)

**Max Noise Level** . . . . . 96 dB(A)

### Shipping Weights

Polypropylene . . . . . 40 lbs (18 kg)

Kynar . . . . . 41 lbs (18.6 kg)

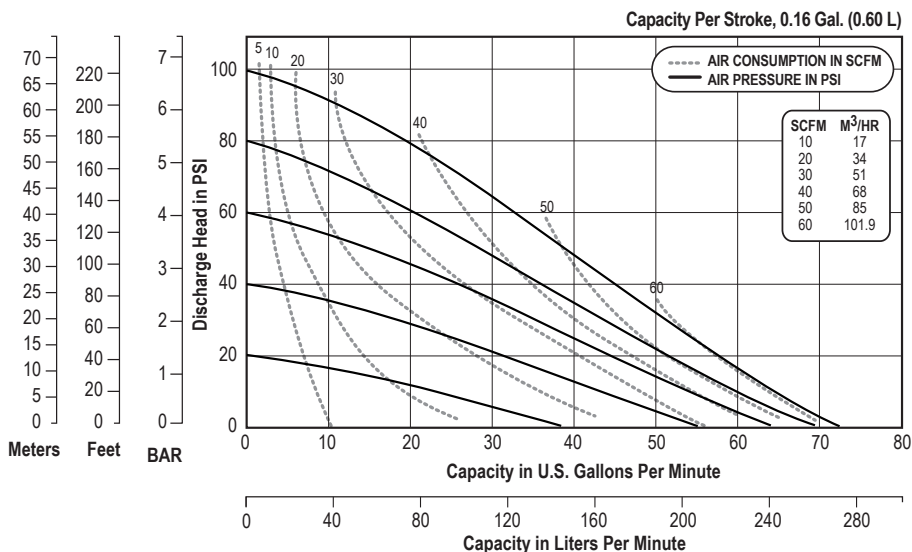

NOTE: Performance based on the following: PTFE fitted pump, flooded suction, water at ambient conditions. The use of other materials and varying hydraulic conditions may result in deviations in excess of 5%.

# Dimensional Drawings

## E4 Plastic

Dimensions in inches (metric dimensions in brackets)

The dimensions on this drawing are for reference only. A certified drawing can be requested if physical dimensions are needed.

1: PUMP SPECS

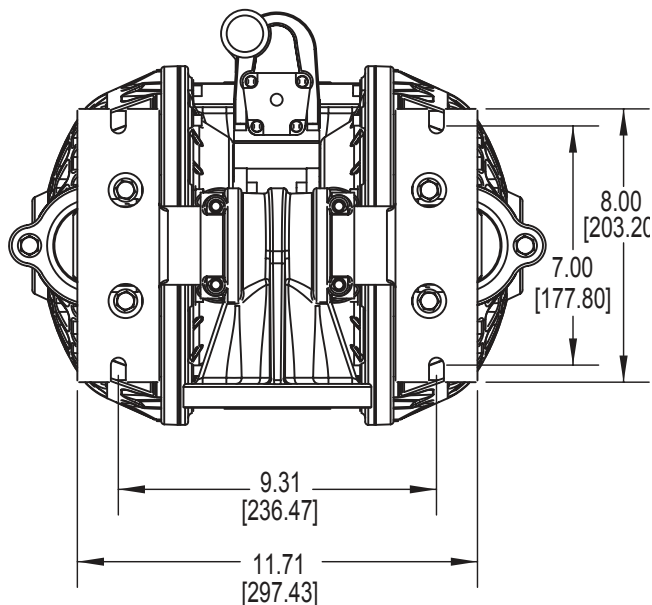
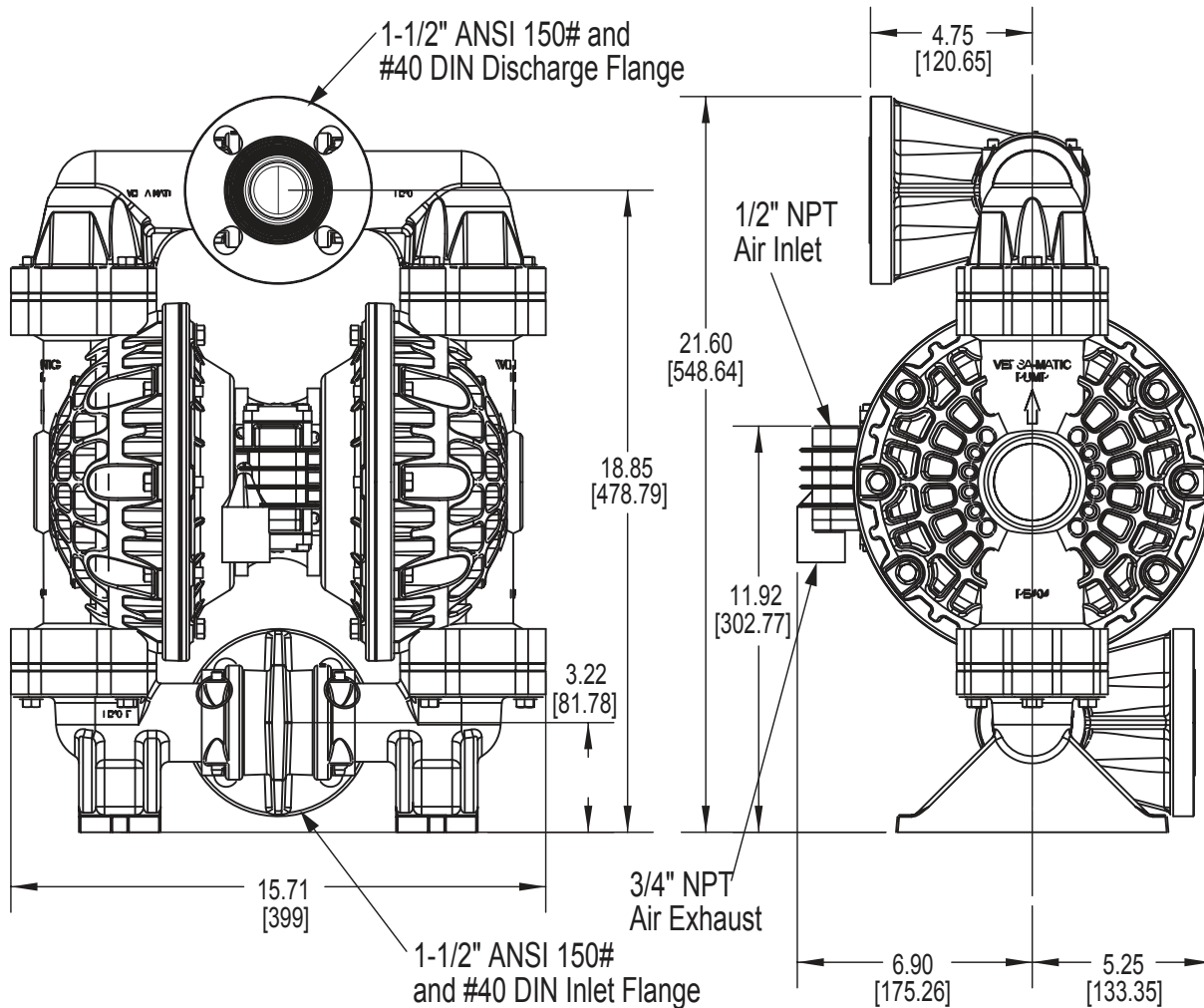

# Principle of Pump Operation

Air-Operated Double Diaphragm (AODD) pumps are powered by compressed air or nitrogen.

The main directional (air) control valve ① distributes compressed air to an air chamber, exerting uniform pressure over the inner surface of the diaphragm ②. At the same time, the exhausting air ③ from behind the opposite diaphragm is directed through the air valve assembly(s) to an exhaust port ④.

As inner chamber pressure (P1) exceeds liquid chamber pressure (P2), the rod ⑤ connected diaphragms shift together creating discharge on one side and suction on the opposite side. The discharged and primed liquid's directions are controlled by the check valves (ball or flap)⑥ orientation.

The pump primes as a result of the suction stroke. The suction stroke lowers the chamber pressure (P3) increasing the chamber volume. This results in a pressure differential necessary for atmospheric pressure (P4) to push the fluid through the suction piping and across the suction side check valve and into the outer fluid chamber ⑦.

Suction (side) stroking also initiates the reciprocating (shifting, stroking or cycling) action of the pump. The suction diaphragm's movement is mechanically pulled through its stroke. The diaphragm's inner plate makes contact with an actuator plunger aligned to shift the pilot signaling valve. Once actuated, the pilot valve sends a pressure signal to the opposite end of the main directional air valve, redirecting the compressed air to the opposite inner chamber.

## SUBMERGED ILLUSTRATION

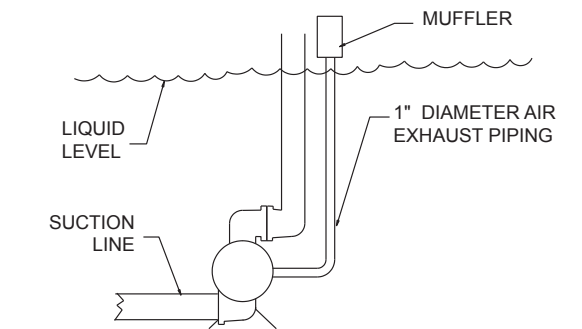

Pump can be submerged if the pump materials of construction are compatible with the liquid being pumped. The air exhaust must be piped above the liquid level. When the pumped product source is at a higher level than the pump (flooded suction condition), pipe the exhaust higher than the product source to prevent siphoning spills.

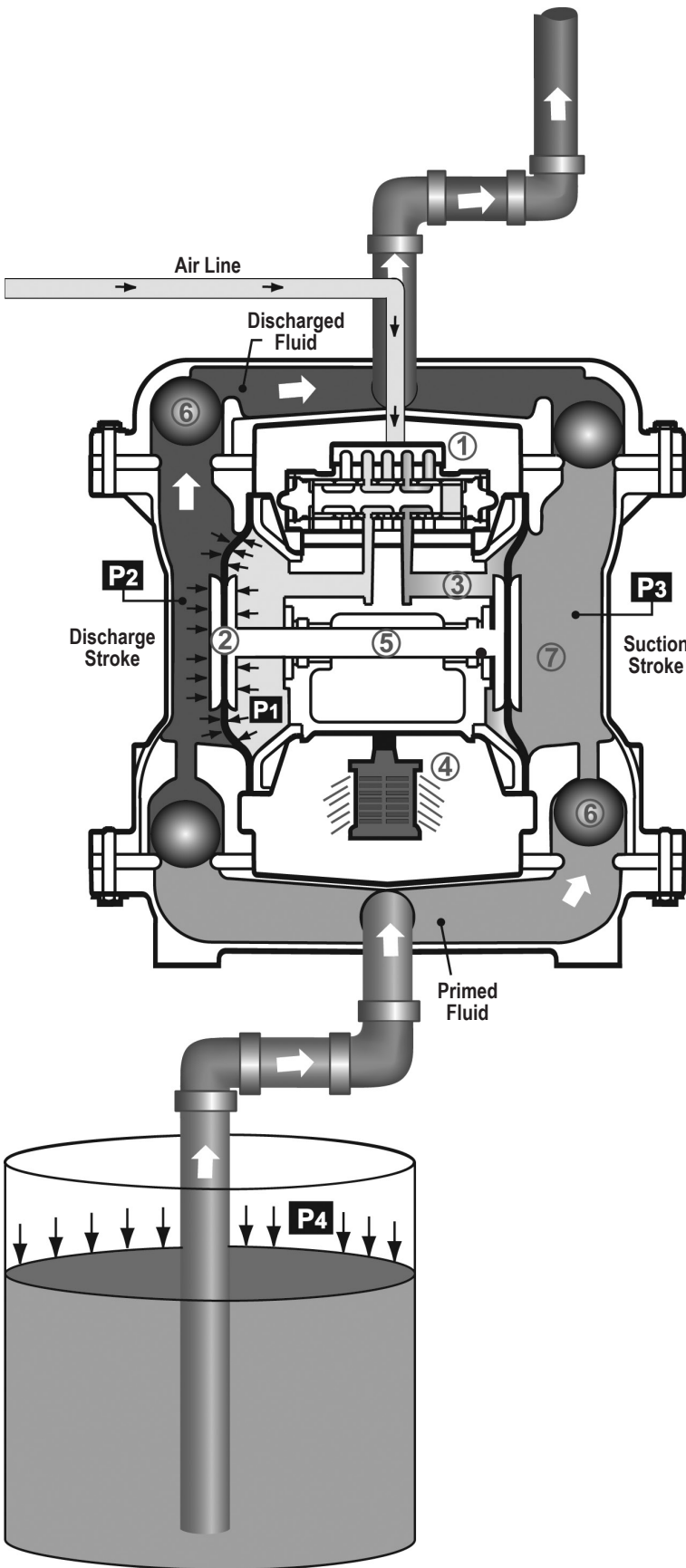

2: INSTAL & OP

# Recommended Installation Guide

## Available Accessories:

1. Surge Suppressor
2. Filter/Regulator
3. Air Dryer
4. Lubricator

**Note:** Surge Suppressor and Piping, including air line, must be supported after the flexible connections.

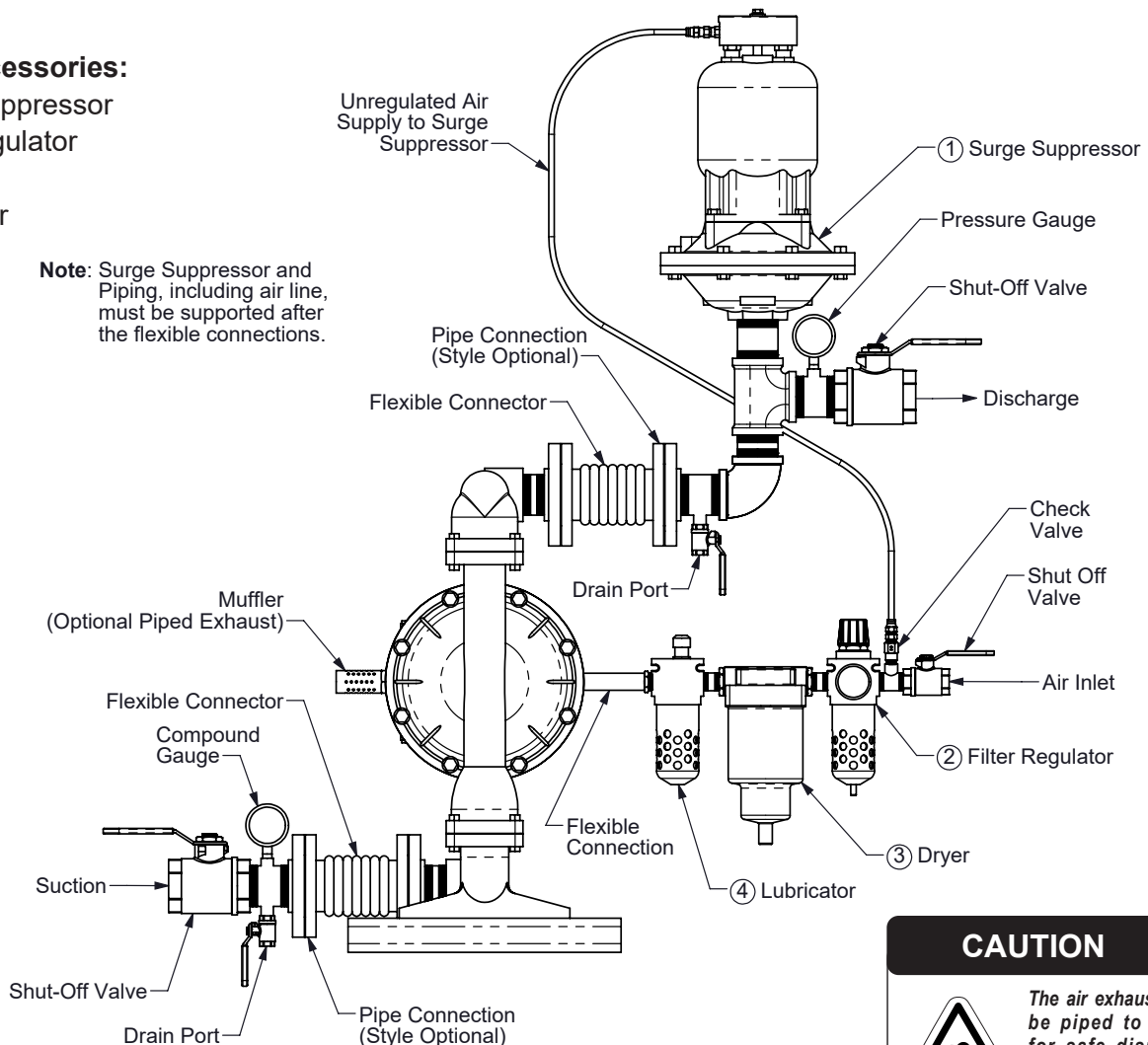

**CAUTION**

The air exhaust should be piped to an area for safe disposition of the product being pumped, in the event of a diaphragm failure.

## Installation And Start-Up

Locate the pump as close to the product being pumped as possible. Keep the suction line length and number of fittings to a minimum. Do not reduce the suction line diameter.

## Air Supply

Connect the pump air inlet to an air supply with sufficient capacity and pressure to achieve desired performance. A pressure regulating valve should be installed to insure air supply pressure does not exceed recommended limits.

## Air Valve Lubrication

The air distribution system is designed to operate **WITHOUT** lubrication. This is the standard mode of operation. If lubrication is desired, install an air line lubricator set to deliver one drop of SAE 10 non-detergent oil for every 20 SCFM (9.4 liters/sec.) of air the pump consumes. Consult the Performance Curve to determine air consumption.

## Air Line Moisture

Water in the compressed air supply may cause icing or freezing of the exhaust air, causing the pump to cycle erratically or stop operating. Water in the air supply can be reduced by using a point-of-use air dryer.

## Air Inlet And Priming

To start the pump, slightly open the air shut-off valve. After the pump primes, the air valve can be opened to increase air flow as desired. If opening the valve increases cycling rate, but does not increase the rate of flow, cavitation has occurred. The valve should be closed slightly to obtain the most efficient air flow to pump flow ratio.

2: INSTAL & OP

# Troubleshooting Guide

Symptom:	Potential Cause(s):	Recommendation(s):
<b>Pump Cycles Once</b>	Deadhead (system pressure meets or exceeds air supply pressure).	Increase the inlet air pressure to the pump. Pump is designed for 1:1 pressure ratio at zero flow. (Does not apply to high pressure 2:1 units).
	Air valve or intermediate gaskets installed incorrectly.	Install gaskets with holes properly aligned.
	Bent or missing actuator plunger.	Remove pilot valve and inspect actuator plungers.
<b>Pump Will Not Operate / Cycle</b>	Pump is over lubricated.	Set lubricator on lowest possible setting or remove. Units are designed for lube free operation.
	Lack of air (line size, PSI, CFM).	Check the air line size and length, compressor capacity (HP vs. cfm required).
	Check air distribution system.	Disassemble and inspect main air distribution valve, pilot valve and pilot valve actuators.
	Discharge line is blocked or clogged manifolds.	Check for inadvertently closed discharge line valves. Clean discharge manifolds/piping.
	Deadhead (system pressure meets or exceeds air supply pressure).	Increase the inlet air pressure to the pump. Pump is designed for 1:1 pressure ratio at zero flow. (Does not apply to high pressure 2:1 units).
	Blocked air exhaust muffler.	Remove muffler screen, clean or de-ice, and re-install.
	Pumped fluid in air exhaust muffler.	Disassemble pump chambers. Inspect for diaphragm rupture or loose diaphragm plate assembly.
<b>Pump Cycles and Will Not Prime or No Flow</b>	Pump chamber is blocked.	Disassemble and inspect wetted chambers. Remove or flush any obstructions.
	Cavitation on suction side.	Check suction condition (move pump closer to product).
	Check valve obstructed. Valve ball(s) not seating properly or sticking.	Disassemble the wet end of the pump and manually dislodge obstruction in the check valve pocket. Clean out around valve ball cage and valve seat area. Replace valve ball or valve seat if damaged. Use heavier valve ball material.
	Valve ball(s) missing (pushed into chamber or manifold).	Worn valve ball or valve seat. Worn fingers in valve ball cage (replace part). Check Chemical Resistance Guide for compatibility.
	Valve ball(s)/seat(s) damaged or attacked by product.	Check Chemical Resistance Guide for compatibility.
	Check valve and/or seat is worn or needs adjusting.	Inspect check valves and seats for wear and proper setting. Replace if necessary.
	Suction line is blocked.	Remove or flush obstruction. Check and clear all suction screens or strainers.
	Excessive suction lift.	For lifts exceeding 20' of liquid, filling the chambers with liquid will prime the pump in most cases.
	Suction side air leakage or air in product.	Visually inspect all suction-side gaskets and pipe connections.
	Pumped fluid in air exhaust muffler.	Disassemble pump chambers. Inspect for diaphragm rupture or loose diaphragm plate assembly.
<b>Pump Cycles Running Sluggish/Stalling, Flow Unsatisfactory</b>	Over lubrication.	Set lubricator on lowest possible setting or remove. Units are designed for lube free operation.
	Icing.	Remove muffler screen, de-ice, and re-install. Install a point of use air drier.
	Clogged manifolds.	Clean manifolds to allow proper air flow
	Deadhead (system pressure meets or exceeds air supply pressure).	Increase the inlet air pressure to the pump. Pump is designed for 1:1 pressure ratio at zero flow. (Does not apply to high pressure 2:1 units).
	Cavitation on suction side.	Check suction (move pump closer to product).
	Lack of air (line size, PSI, CFM).	Check the air line size, length, compressor capacity.
	Excessive suction lift.	For lifts exceeding 20' of liquid, filling the chambers with liquid will prime the pump in most cases.
	Air supply pressure or volume exceeds system hd.	Decrease inlet air (press. and vol.) to the pump. Pump is cavitating the fluid by fast cycling.
	Undersized suction line.	Meet or exceed pump connections.
	Restrictive or undersized air line.	Install a larger air line and connection.
	Suction side air leakage or air in product.	Visually inspect all suction-side gaskets and pipe connections.
	Suction line is blocked.	Remove or flush obstruction. Check and clear all suction screens or strainers.
	Pumped fluid in air exhaust muffler.	Disassemble pump chambers. Inspect for diaphragm rupture or loose diaphragm plate assembly.
	Check valve obstructed.	Disassemble the wet end of the pump and manually dislodge obstruction in the check valve pocket.
	Check valve and/or seat is worn or needs adjusting.	Inspect check valves and seats for wear and proper setting. Replace if necessary.
<b>Product Leaking Through Exhaust</b>	Entrained air or vapor lock in chamber(s).	Purge chambers through tapped chamber vent plugs. Purging the chambers of air can be dangerous.
	Diaphragm failure, or diaphragm plates loose.	Replace diaphragms, check for damage and ensure diaphragm plates are tight.
<b>Premature Diaphragm Failure</b>	Diaphragm stretched around center hole or bolt holes.	Check for excessive inlet pressure or air pressure. Consult Chemical Resistance Chart for compatibility with products, cleaners, temperature limitations and lubrication.
	Cavitation.	Enlarge pipe diameter on suction side of pump.
	Excessive flooded suction pressure.	Move pump closer to product. Raise pump/place pump on top of tank to reduce inlet pressure. Install Back pressure device (Tech bulletin 41r). Add accumulation tank or pulsation dampener.
	Misapplication (chemical/physical incompatibility).	Consult Chemical Resistance Chart for compatibility with products, cleaners, temperature limitations and lubrication.
<b>Unbalanced Cycling</b>	Incorrect diaphragm plates or plates on backwards, installed incorrectly or worn.	Check Operating Manual to check for correct part and installation. Ensure outer plates have not been worn to a sharp edge.
	Excessive suction lift.	For lifts exceeding 20' of liquid, filling the chambers with liquid will prime the pump in most cases.
	Undersized suction line.	Meet or exceed pump connections.
	Pumped fluid in air exhaust muffler.	Disassemble pump chambers. Inspect for diaphragm rupture or loose diaphragm plate assembly.
	Suction side air leakage or air in product.	Visually inspect all suction-side gaskets and pipe connections.
	Check valve obstructed.	Disassemble the wet end of the pump and manually dislodge obstruction in the check valve pocket.
<b>Unbalanced Cycling</b>	Check valve and/or seat is worn or needs adjusting.	Inspect check valves and seats for wear and proper setting. Replace if necessary.
	Entrained air or vapor lock in chamber(s).	Purge chambers through tapped chamber vent plugs.

For additional troubleshooting tips contact After Sales Support at [service.warrenrupp@idexcorp.com](mailto:service.warrenrupp@idexcorp.com) or 419-524-8388

2: INSTAL & OP

# Composite Repair Parts Drawing

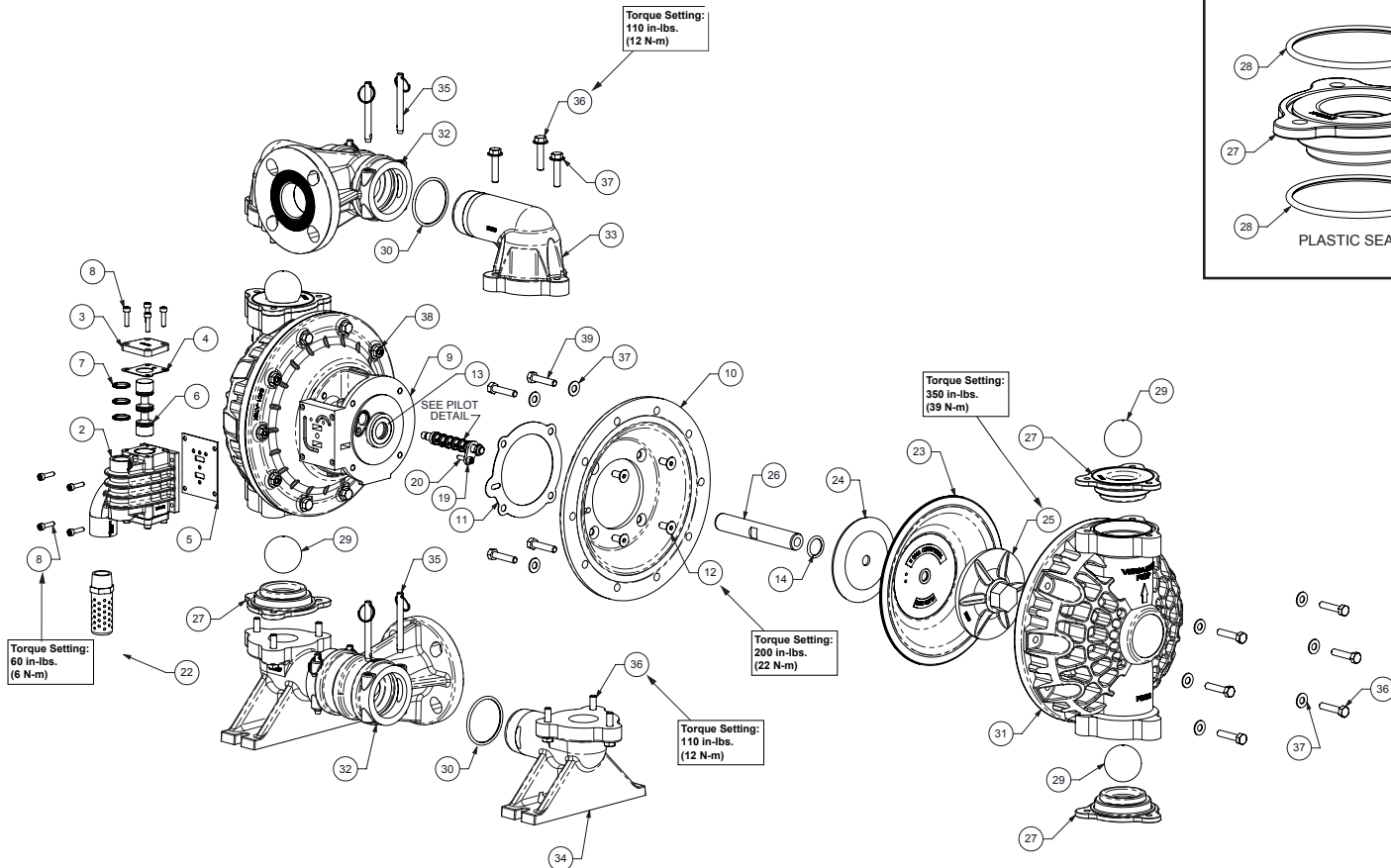
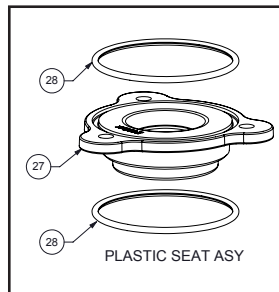
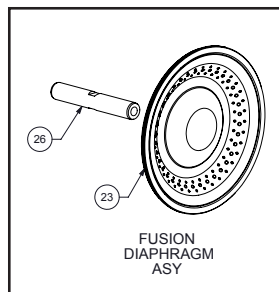
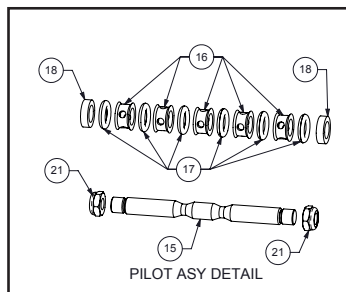

3: EXP VIEW

# Composite Repair Parts List

Air Valve Assembly						
Item #	Qty.	Description	Part Number			
			Aluminum	Nickel Plated	PTFE Coated	
1	-	Valve Body Assembly (includes items 2-7)	P31-200	P31-200-NP	P31-200TC	
2	1	Valve Body w/ Sleeve	P31-200 ASY	P31-201NP	P31-201TC	
3	2	End Cap	P50-300	P50-300NP	P50-300TC	
4	2	End Cap Gasket		P50-110		
5	1	Valve Body Gasket		P31-202		
6	1	Valve Spool		P50-104		
7	3	Glyde Ring Assembly		P50-104C		
8	12	Mounting Screws		S1001		
Center Section Assembly						
Item #	Qty.	Description	Part Number			
			Aluminum	Nickel Plated	PTFE Coated	
9	1	Center Block Assembly (Includes item 13 & 14)	P31-400DC ASY	P31-401NP	P31-401TC	
10	2	Air Chamber	E401	E401NP	E401TC	
11	2	Air Chamber Gasket		P31-109		
12	8	Bolt		P31-404		
13	2	Bearing Sleeve		P31-403		
14	2	Main Shaft O-Ring		P24-403		
15	1	Pilot Shaft		P50-112		
16	5	Pilot Spacer		P24-106P		
17	6	Pilot O-Ring		P24-107		
18	2	Pilot Ring		P50-119		
19	2	Pilot Retainer		P50-109		
20	2	Screw		S1001		
21	2	Stop Nut		P24-108		
22	1	Muffler		530.026.000		
Diaphragm Assembly / Elastomers						
Item #	Qty.	Description	Part Number			
			Polypropylene		PVDF	
			Versa-Rugged	Fusion	Versa-Rugged	Fusion
23	2	Diaphragm (See Below Material Chart)	V163xx	V163F	V163xx	V163F
24	2	Inner Diaphragm Plate (See Note 2 Below)	E414, E414TC	N/A	E414, E414TC	N/A
25	2	Outer Diaphragm Plate (See Note 1 Below)	PE413	N/A	KE413	N/A
26	1	Main Shaft		P31-103		
27	4	Valve Seat (See Below Material Chart)		E408xx		
28	8	Seat O-ring (See note 3 Below)		E412TES		
29	4	Valve Ball (See Below Material Chart)		V171xx		
30	4	Manifold Tee O-Ring		E413xx		
Wet End Assembly						
Item #	Qty.	Description	Part Number			
			Polypropylene		PVDF	
31	2	Water Chamber	PE404		KE404	
32	2	Manifold Tee	PE411		KE411	
33	2	Discharge Elbow	PE409		KE409	
34	2	Suction Elbow	PE409F		KE409F	
35	8	Detent Pin		E417		
36	24	Bolt		SV187A		
37	32	Washer		SV189C		
38	12	Nut		SV185B		
39	8	Water Chamber Bolt (Short)		SV185A		
Elastomer Material Specifications						
Material	Versa-Rugged Diaphragm P/N	"Ball P/N"	Seat P/N	"Seat O-Ring P/N"	"Manifold Tee O-Ring P/N"	
Neoprene	V163N	V171N	E408N	N/A	N/A	
Nitrile	V163BN	V171BN	E408BN	N/A	E413BN	
FKM	V163VT	V171VT	E408VT	N/A	E413VT	
EPDM	V163ND	V171ND	E408ND	N/A	E413ND	
PTFE	N/A	V171TF	N/A	E412TES	E413TES	
Santoprene	V163TPEXL	V171TPEXL	E408XL	N/A	E413XL	
Hytrel	V163TPEFG	V171TPEFG	E408FG	N/A	N/A	
Geolast	V163G	V171G	N/A	N/A	N/A	
Polypropylene	N/A	N/A	E408P (See Note 3)	N/A	N/A	
PVDF	N/A	N/A	E408K (See Note 3)	N/A	N/A	

3: EXP VIEW

**Notes:**

- 1.) The outer diaphragm plate material is to match the water chamber material
- 2.) The inner diaphragm plate material is to match the air chamber material
- 3.) These o-ring are only used with valve seats
- 4.) TC=PTFE Coated, NP=Nickel Plated

## Material Codes - The Last 3 Digits of Part Number

000.....Assembly, sub-assembly; and some purchased items	364.....EPDM Rubber Color coded: BLUE
010.....Cast Iron	365.....Neoprene Rubber Color coded: GREEN
015.....Ductile Iron	366.....Food Grade Nitrile
020.....Ferritic Malleable Iron	368.....Food Grade EPDM
080.....Carbon Steel, AISI B-1112	371.....Philthane (Tuftane)
110.....Alloy Type 316 Stainless Steel	374.....Carboxylated Nitrile
111.....Alloy Type 316 Stainless Steel (Electro Polished)	375.....Fluorinated Nitrile
112.....Alloy C	378.....High Density Polypropylene
113.....Alloy Type 316 Stainless Steel (Hand Polished)	379.....Conductive Nitrile
114.....303 Stainless Steel	408.....Cork and Neoprene
115.....302/304 Stainless Steel	425.....Compressed Fibre
117.....440-C Stainless Steel (Martensitic)	426.....Blue Gard
120.....416 Stainless Steel (Wrought Martensitic)	440.....Vegetable Fibre
148.....Hardcoat Anodized Aluminum	500.....Delrin® 500
150.....6061-T6 Aluminum	502.....Conductive Acetal, ESD-800
152.....2024-T4 Aluminum (2023-T351)	503.....Conductive Acetal, Glass-Filled
155.....356-T6 Aluminum	506.....Delrin® 150
156.....356-T6 Aluminum	520.....Injection Molded PVDF Natural color
157.....Die Cast Aluminum Alloy #380	540.....Nylon
158.....Aluminum Alloy SR-319	542.....Nylon
162.....Brass, Yellow, Screw Machine Stock	544.....Nylon Injection Molded
165.....Cast Bronze, 85-5-5-5	550.....Polyethylene
166.....Bronze, SAE 660	551.....Glass Filled Polypropylene
170.....Bronze, Bearing Type, Oil Impregnated	552.....Unfilled Polypropylene
180.....Copper Alloy	555.....Polyvinyl Chloride
305.....Carbon Steel, Black Epoxy Coated	556.....Black Vinyl
306.....Carbon Steel, Black PTFE Coated	558.....Conductive HDPE
307.....Aluminum, Black Epoxy Coated	570.....Rulon II®
308.....Stainless Steel, Black PTFE Coated	580.....Ryton®
309.....Aluminum, Black PTFE Coated	600.....PTFE (virgin material) Tetrafluorocarbon (TFE)
313.....Aluminum, White Epoxy Coated	603.....Blue Gylon®
330.....Zinc Plated Steel	604.....PTFE
332.....Aluminum, Electroless Nickel Plated	606.....PTFE
333.....Carbon Steel, Electroless Nickel Plated	607.....Envelon
335.....Galvanized Steel	608.....Conductive PTFE
337.....Silver Plated Steel	610.....PTFE Encapsulated Silicon
351.....Food Grade Santoprene®	611.....PTFE Encapsulated FKM
353.....Geolast; Color: Black	632.....Neoprene/Hytrel®
354.....Injection Molded #203-40 Santoprene® Duro 40D +/-5; Color: RED	633.....FKM/PTFE
356.....Hytrel®	634.....EPDM/PTFE
357.....Injection Molded Polyurethane	635.....Neoprene/PTFE
358.....Urethane Rubber (Some Applications) (Compression Mold)	637.....PTFE, FKM/PTFE
359.....Urethane Rubber	638.....PTFE, Hytrel®/PTFE
360.....Nitrile Rubber Color coded: RED	639.....Nitrile/TFE
363.....FKM (Fluorocarbon) Color coded: YELLOW	643.....Santoprene®/EPDM
	644.....Santoprene®/PTFE
	656.....Santoprene® Diaphragm and Check Balls/EPDM Seats
	661.....EPDM/Santoprene®
	666.....FDA Nitrile Diaphragm, PTFE Overlay, Balls, and Seals
	668.....PTFE, FDA Santoprene®/PTFE

- Delrin and Hytrel are registered tradenames of E.I. DuPont.
- Nylatron is a registered tradename of Polymer Corp.
- Gylon is a registered tradename of Garlock, Inc.
- Santoprene is a registered tradename of Exxon Mobil Corp.
- Rulon II is a registered tradename of Dixon Industries Corp.
- Ryton is a registered tradename of Phillips Chemical Co.
- Valox is a registered tradename of General Electric Co.

## RECYCLING

Warren Rupp, manufacturer of Versamatic, is an ISO14001 registered company and is committed to minimizing the impact our products have on the environment. Many components of Versamatic® AODD pumps are made of recyclable materials. We encourage pump users to recycle worn out parts and pumps whenever possible, after any hazardous pumped fluids are thoroughly flushed. Pump users that recycle will gain the satisfaction to know that their discarded part(s) or pump will not end up in a landfill. The recyclability of Versamatic products is a vital part of Warren Rupp's commitment to environmental stewardship.

# 5 - YEAR Limited Product Warranty

Quality System ISO9001 Certified • Environmental Management Systems ISO14001 Certified

*Versamatic warrants to the original end-use purchaser that no product sold by Versamatic that bears a Versamatic brand shall fail under normal use and service due to a defect in material or workmanship within five years from the date of shipment from Versamatic's factory.*

*The use of non-OEM replacement parts will void (or negate) agency certifications, including CE, ATEX, CSA, 3A and EC1935 compliance (Food Contact Materials). Warren Rupp, Inc. cannot ensure nor warrant non-OEM parts to meet the stringent requirements of the certifying agencies.*

~ See complete warranty at <https://www.versamatic.com/>



## EC Declaration of Conformity

**Manufacturer:**  
**Warren Rupp, Inc.**  
**800 N. Main Street**  
**Mansfield, Ohio, 44902 USA**

Certifies that Air-Operated Double Diaphragm Pump Models: E Series, VL Series, VM Series, U2 Series; Submersible Pump Models: VSMA3 Series, SPA15 Series and Surge Dampener/Suppressor Models: VDA Series, VTA Series comply with the European Community Directive 2006/42/EC on Machinery, according to Annex VIII. This product has used Harmonized Standard EN809:2012, Pumps and Pump Units for Liquids - Common Safety Requirements, to verify conformance.

October 3, 2022

DATE/APPROVAL/TITLE:

Technical File on record with:  
DEKRA Certification B.V.  
Meander 1051  
6825 MJ Arnhem  
The Netherlands

  
Signature of authorized person

Dennis Hall  
Printed name of authorized person

Engineering Manager  
Title





## EC Declaration of Conformity

**Manufacturer:**  
**Warren Rupp, Inc.**  
**800 N. Main Street**  
**Mansfield, Ohio, 44902 USA**

Certifies that Air-Operated Double Diaphragm Pump Models: E Series, VL Series, VM Series, U2 Series; Submersible Pump Models: VSMA3 Series, SPA15 Series and Surge Dampener/Suppressor Models: VDA Series, VTA Series comply with the United Kingdom Statutory Instruments 2008 No. 1597, The Supply of Machinery (Safety) Regulations 2008, according to Annex VIII. This product has used Designated Standard EN809:2012, Pumps and Pump Units for Liquids - Common Safety Requirements, to verify conformance.

October 17, 2022

DATE/APPROVAL/TITLE:

Technical File on record with:  
DEKRA Certification UK Limited  
Stokenchurch House  
Oxford Road  
Stokenchurch  
HP14 3SX

Signature of authorized person

Dennis Hall

Printed name of authorized person

Engineering Manager

Title

