

E3AA2R229C-ATEX					
Material Mediumsberührt:	Aluminium				
Material Mittelteil:	Aluminium				
Material Membrane:	Nitril				
Anschluss:	NPT Innen Gewinde				

Luftventil Ersatzteile

Pos	Bezeichnung	Stk	Art Nr.	Air-Kit	Wet-Kit	URL
	Luftseite Reperatur Kit (inkl. Pos. 3, 5, 7, 9, 14, 16, 18-22)		476.V029.000	✓		https://aodd-pumpen.de/476-V029-000
1	Luftventilbaugruppe (inkl. Pos. 2-11)	1	031.V003.156			https://aodd-pumpen.de/031-V003-156
2	Ventilkörper	1	095.V001.156			https://aodd-pumpen.de/095-V001-156
3	Ventilkörperdichtung	1	P24-202	✓		https://aodd-pumpen.de/P24-202
4	Ventilhülse	1	755.V006.148			https://aodd-pumpen.de/755-V006-148
5	O-Ringe	6	560.206.360	✓		https://aodd-pumpen.de/560206360
6	Ventilschieber-ASY (inkl. Pos. 7)	1	775.V001.000			https://aodd-pumpen.de/775-V001-000
7	Glyd Ring ASY	6	P34-204F	✓		https://aodd-pumpen.de/P34-204F
8	Luftventilschirm	1	P24-210			https://aodd-pumpen.de/P24-210
9	Endkappen-Dichtung	2	P24-205	✓		https://aodd-pumpen.de/P24-205
10	Endkappen	2	P34-300			https://aodd-pumpen.de/P34-300
11	Montageschrauben	13	S1001			https://aodd-pumpen.de/S1001

Mittelteil Ersatzteile

Pos	Bezeichnung	Stk	Art Nr.	Air-Kit	Wet-Kit	URL
12	Mittelblock (inkl. Pos. 13&14)	1	P34-400DC ASY			https://aodd-pumpen.de/P34-400DC-ASY
13	Lagerhülse	2	P34-404			https://aodd-pumpen.de/P34-404
14	O-Ring Hauptwelle	2	P34-403	✓		https://aodd-pumpen.de/P34-403
15	Luftkammer	2	196.V008.157			https://aodd-pumpen.de/196-V008-157
16	Luftkammerdichtung	2	P79-109	✓		https://aodd-pumpen.de/P79-109
17	Schraube	8	P24-110			https://aodd-pumpen.de/P24-110
	Pilot-Reparatursatz (inkl. Pos. 18-22)		476.V028.000			https://aodd-pumpen.de/476-V028-000
18	Pilothülsen ASY (inkl. Pos. 19)	1	755.V002.000	✓		https://aodd-pumpen.de/755-V002-000
19	O-Ring	6	560.101.358	✓		https://aodd-pumpen.de/560101358
20	Sicherungsring	1	675.037.080	✓		https://aodd-pumpen.de/675037080
21	Pilotkolben ASY (inkl. Pos. 22)	1	775.V006.000	✓		https://aodd-pumpen.de/775-V006-000
22	O-Ring	8	560.023.358	✓		https://aodd-pumpen.de/560023358
23	Schalldämpfer	1	530.033.000			https://aodd-pumpen.de/530033000

Membranen Ersatzteile

Pos	Bezeichnung	Stk	Art Nr.	Air-Kit	Wet-Kit	URL
	Rep. Satz Membrane (inkl. Pos. 25, 32, 33)		476.V024.360		✓	https://aodd-pumpen.de/476-V024-360
24	Hauptwelle	1	P34-103	✓		https://aodd-pumpen.de/P34-103
25	Membrane	2	V305BN		✓	https://aodd-pumpen.de/V305BN
26	Äußere Membranplatte	2	V302BDC			https://aodd-pumpen.de/V302BDC
27	Innerer Membranplatte	2	V302CDC			https://aodd-pumpen.de/V302CDC
28	Schraube	12	V302G			https://aodd-pumpen.de/V302G
29	U-Scheibe	12	V302GA			https://aodd-pumpen.de/V302GA
30	U-Scheibe für Stoßfänger	2	P34-501			https://aodd-pumpen.de/P34-501
31	Back-Up U-Scheibe	2	V302E			https://aodd-pumpen.de/V302E
32	Ventilsitz	4	V456BN		✓	https://aodd-pumpen.de/V456BN
33	Ventilball	4	V455BN		✓	https://aodd-pumpen.de/V455BN

Mediumsberührte Ersatzteile

Pos	Bezeichnung	Stk	Art Nr.	Air-Kit	Wet-Kit	URL
34	Wasserkammer	2	V350FB			https://aodd-pumpen.de/V350FB
35	Schraube für Wasserkammer	20	170.055.330			https://aodd-pumpen.de/170055330
36	Mutter	52	V387C			https://aodd-pumpen.de/V387C
37	U-Scheibe	52	V387B			https://aodd-pumpen.de/V387B
38	Verteiler-T-Stück	2	V358FB			https://aodd-pumpen.de/V358FB
39	Winkelstück für Auslass	2	V351E-FB			https://aodd-pumpen.de/V351E-FB
40	Winkelstück für Einlass	2	V352E-FB			https://aodd-pumpen.de/V352E-FB
41	O-Ring	4	V258BN			https://aodd-pumpen.de/V258BN
42	Schraube für Krümmer	32	V387D			https://aodd-pumpen.de/V387D
43	Auslassverteiler	1	518.V002.156			https://aodd-pumpen.de/518-V002-156
44	Einlassverteiler	1	518.V003.156			https://aodd-pumpen.de/518-V003-156

Option: Anschlüsse und Zubehör

Pos	Bezeichnung	Stk	Art Nr.	Air-Kit	Wet-Kit	URL
	Schmierfett	1	508.002.000	✓	✓	https://aodd-pumpen.de/508-002-000
	Warnzettel	1	485.017.000			https://aodd-pumpen.de/485017000

Composite Repair Parts Drawing - Elastomeric and TPE Fitted

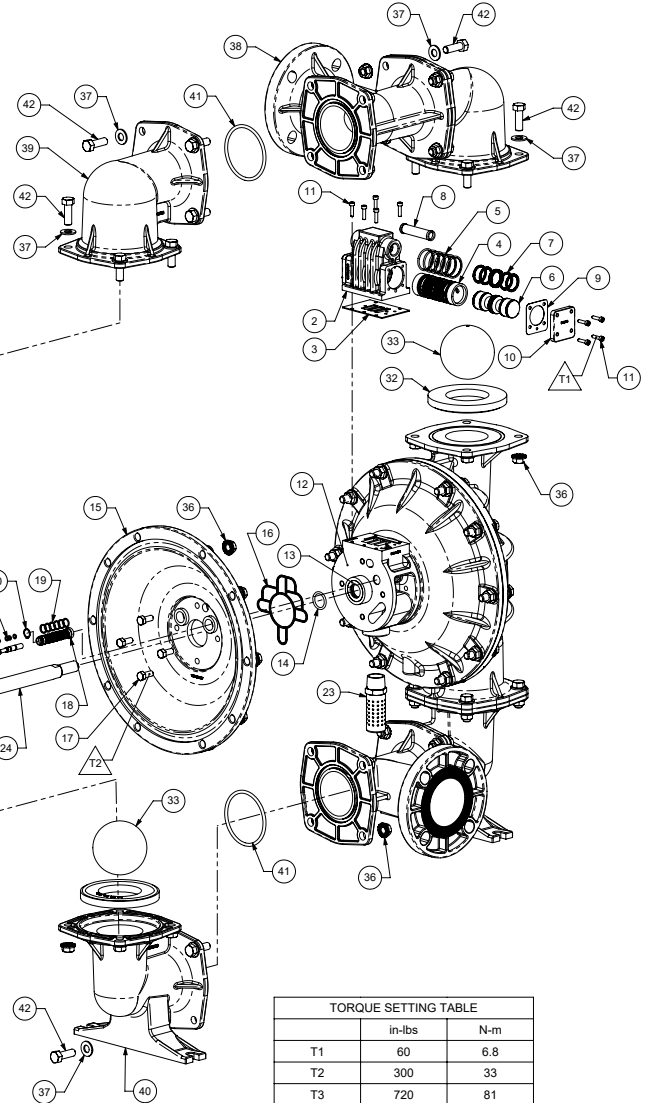
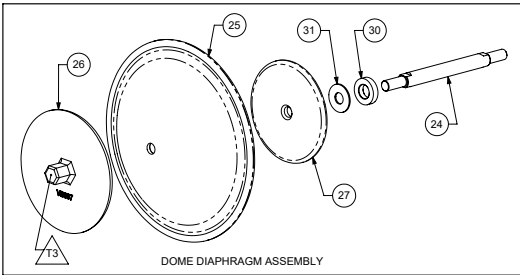
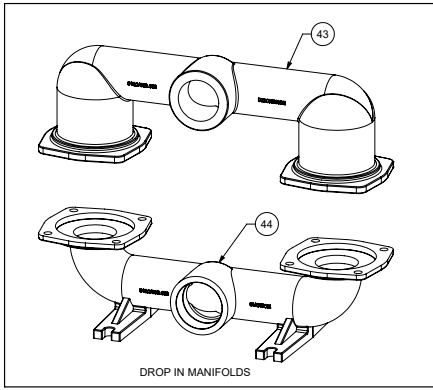

TORQUE SETTING TABLE		
	in-lbs	N-m
T1	60	6.8
T2	300	33
T3	720	81



Optional orientation:
To ease assembly of the TPE diaphragms,
one of the diaphragms may be reversed.

3: EXP VIEW